

MODEL 8760 RR TRACK SCALE
SIDE VIEW OF DOUBLE UNIT MODULES

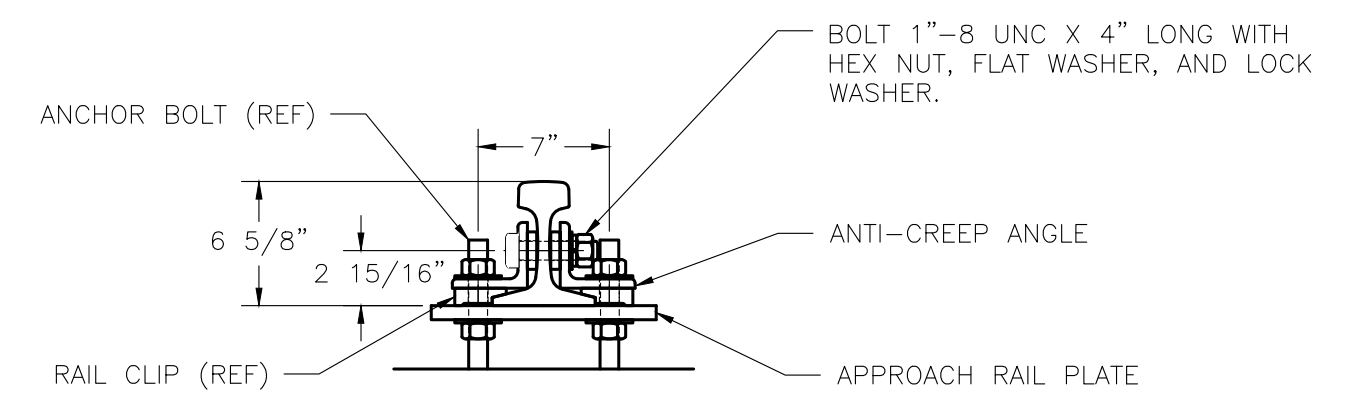

DETAIL
APPROACH ANTI-CREEP ASSEMBLY
ANTI-CREEP ASSEMBLIES ARE TO BE INSTALLED AT CENTER OF EACH SCALE MODULE AND AT ALL SCALE ENDS OF ALL APPROACHES.

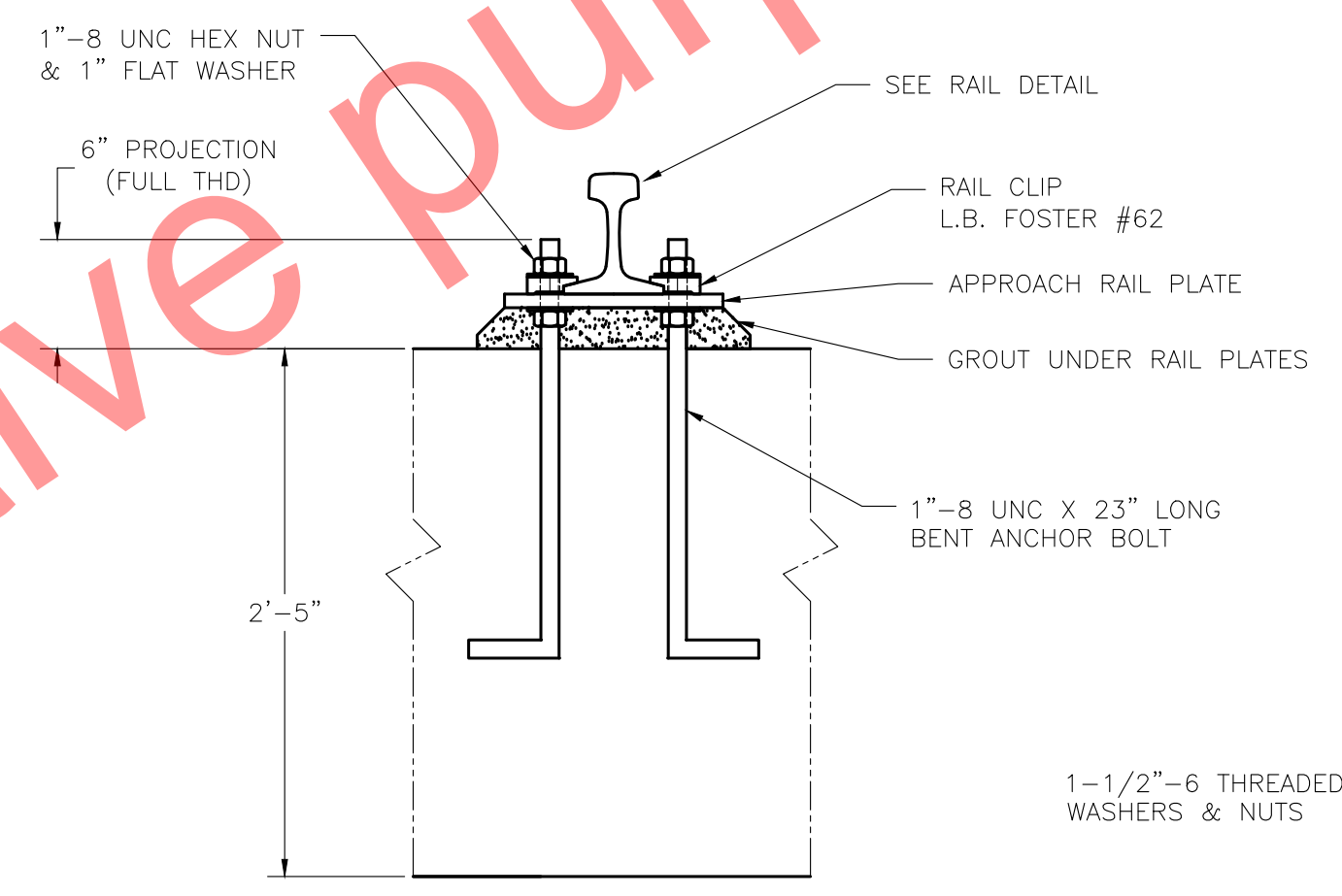

TYP APPROACH RAIL MOUNT

ANCHOR BOLTS MUST BE POURED IN PLACE WITH HARDWARE AS SHOWN. USE GROUT PLATE OR TEMPLATE TO HOLD CENTERS. DO NOT GROUT PLATES UNTIL SCALE IS INSTALLED AND LEVELED WITH APPROACH RAILS.

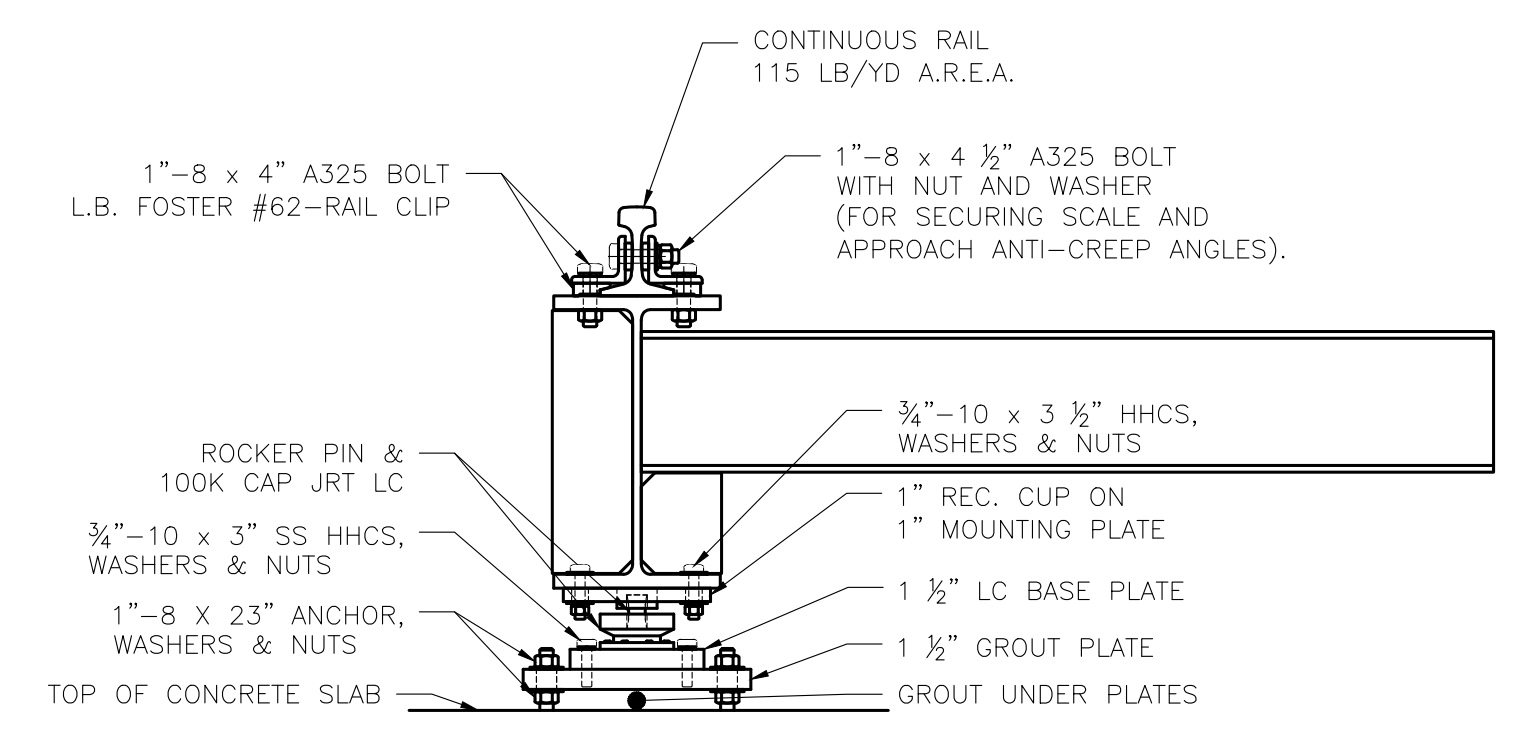

MODEL 8760 RR TRACK SCALE
CROSS SECTION VIEW (PARTIAL)

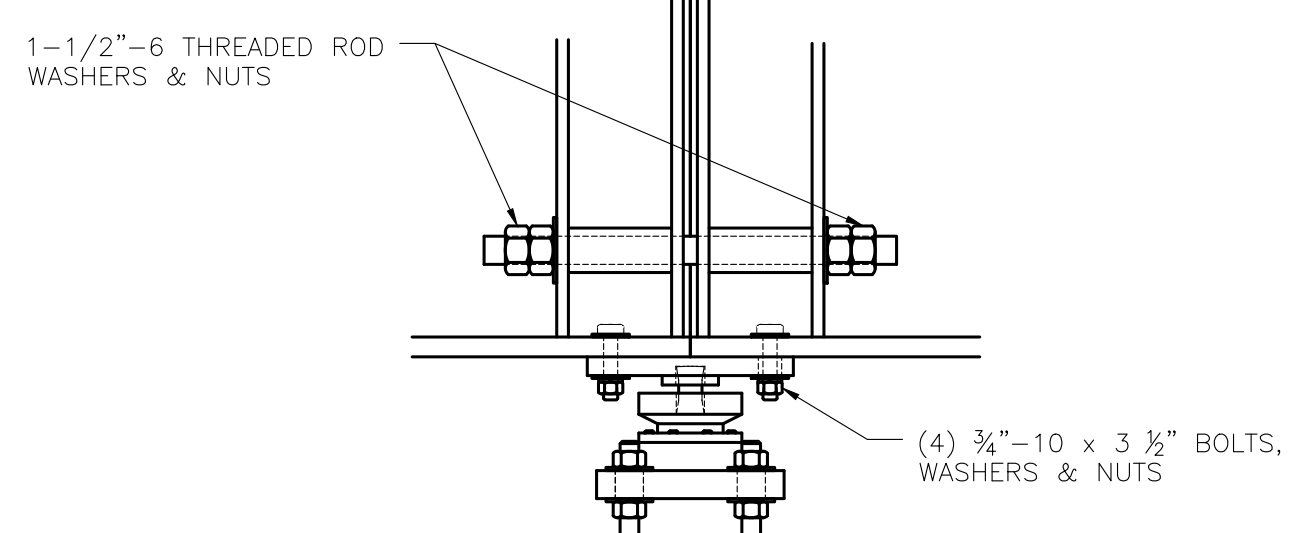

CONNECTION DETAIL

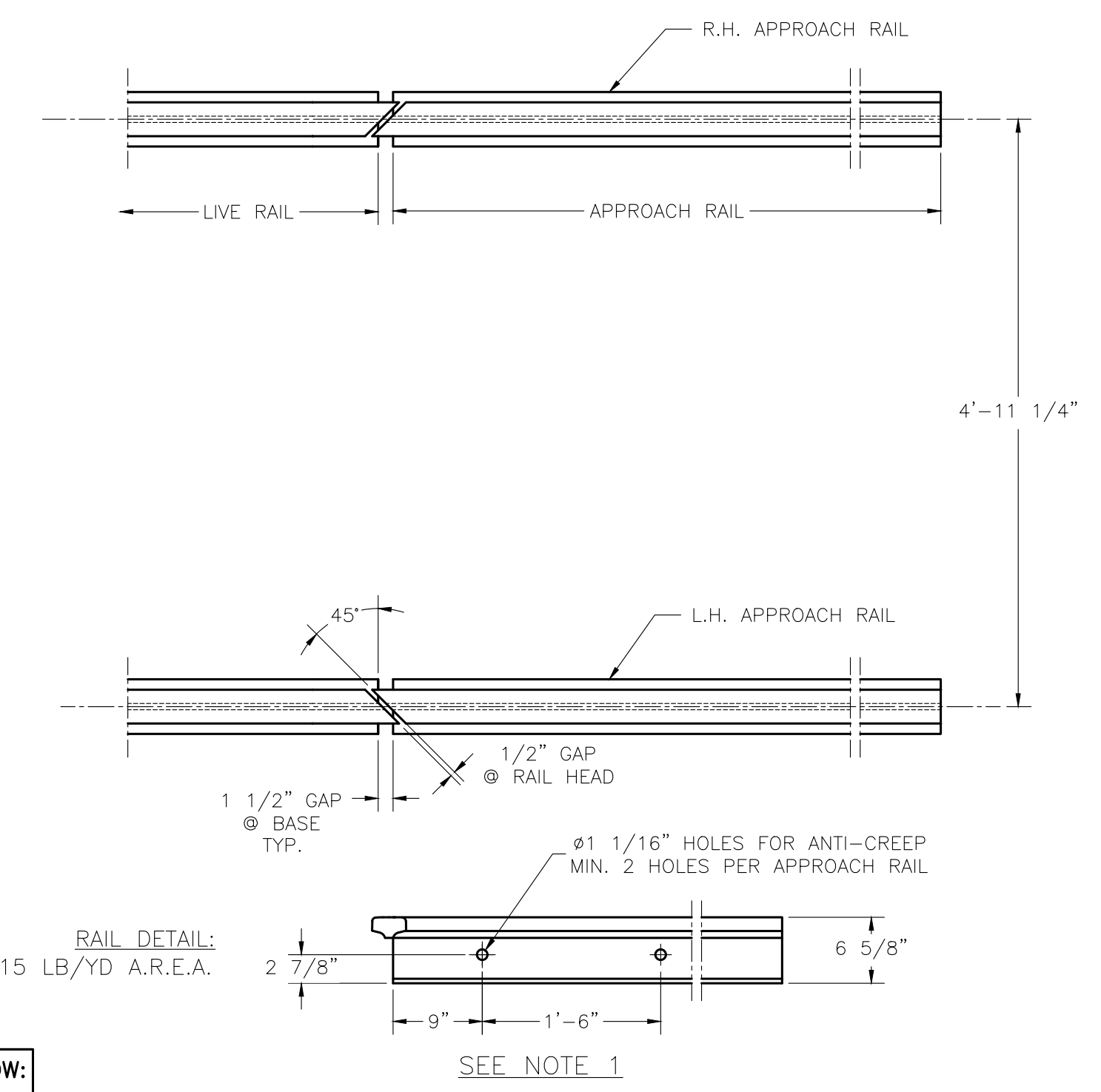

- NOTES**
1. TO ASSURE PROPER FIT, APPROACH RAILS MUST BE DRILLED (FOR ANTI-CREEP DEVICES) IN THE FIELD. AFTER THE RAIL IS LOCATED IN PLACE, USE THE ANTI-CREEP DEVICE AS A TEMPLATE TO LOCATE THE HOLES THROUGH THE RAIL WEB.
 2. RAIL IS NOT SUPPLIED BY THURMAN SCALE COMPANY. ANCHOR BOLTS, ANTI-CREEP DEVICES, RAIL PLATES AND RAIL CLIPS FOR THE APPROACHES ARE INCLUDED IN THE OPTIONAL APPROACH KIT AND WILL BE SUPPLIED BY THURMAN SCALE COMPANY ONLY WHEN SPECIFIED ON THE SALES ORDER. ANCHOR BOLTS FOR THE SCALE ARE ALSO AVAILABLE IN AN OPTIONAL KIT AVAILABLE THROUGH THURMAN SCALE COMPANY.
 3. GROUND RODS LABELED "SGR" ARE SUPPLIED BY THURMAN SCALE AS FOUNDATION EMBED ITEMS. THESE GROUND RODS ARE INTENDED TO BE USED AS PART OF THE SCALE GROUNDING KIT. GROUND EACH PLATFORM AND THE POWER SUPPLY WITH SEPERATE GROUNDS.
 4. GROUTING: APPROACH RAIL PLATES AND SCALE GROUT PLATES MUST BE GROUTED IN PLACE AFTER WEIGHBRIDGES, LOADCELLS AND APPROACH RAILS ARE IN CORRECT WEIGHING POSITION. USE BEST AVAILABLE TYPE GROUT TO DEVELOP 10,000 PSI COMPRESSIVE STRENGTH. FOLLOW THE GROUT MANUFACTURER INSTRUCTIONS FOR SURFACE PREPARATION, FORMS, MIXING AND PLACEMENT PROCEDURES.

THIS DRAWING IS SUPPLIED AS CHECKED BELOW:

REFERENCE (ESTIMATES ONLY, NOT FOR CONSTRUCTION)

CERTIFIED FOR CONSTRUCTION, THURMAN SERIAL#

CUSTOMER: _____ DATE: _____

CUSTOMER P.O.# _____

CUSTOMER APPROVAL, RETURN ONE COPY.

ORDER ON HOLD UNTIL SIGNED COPY IS RETURNED

APPROVED AS DRAWN, APPROVED BY: _____ DATE: _____

APPROVED AS NOTED, APPROVED BY: _____ DATE: _____

THE INFORMATION CONTAINED HEREIN AND IN ANY OTHER DRAWINGS OR SPECIFICATIONS IS THE PROPERTY OF THURMAN SCALE. IT IS TO BE USED ONLY FOR THE PROJECT AND SITE SPECIFICALLY IDENTIFIED IN THIS DOCUMENT. THURMAN SCALE ASSUMES NO RESPONSIBILITY FOR ERRORS OR OMISSIONS IN THIS DOCUMENT AFTER ORIGINAL TRANSMISSION.

UNLESS OTHERWISE SPECIFIED, DIMENSIONS IN INCHES AND FRACTIONS ARE AS FOLLOWS:
INCHES: AS FOLLOWS
FRACTIONS: AS FOLLOWS
3-PLACE DECIMAL: #1/8
2-PLACE DECIMAL: #1/16
HOLE DIMETERS: #1/32

8760 RRT SCALE
DOUBLE CONFIGURATION
25'-0" LIVE RAIL
115#/YD A.R.E.A. RAIL

THURMAN SCALE

SCALE: NTS DRAWN: LDC CHECKED: _____
SHEET: 2 OF 2 DATE: 2/11/15 APPROVED: _____
DRAWING NUMBER: 92722-AS

MODEL: 8760