

## TS255 SERIES KEYPAD INSTRUMENT



Thurman Scale's TS255 Series Instrument with keypad for easy ID entry and configuration is available in a rugged black ABS plastic or 304 series stainless steel enclosure. It is the perfect companion for Thurman's Avenger® floor scales and is equally reliable when used with tank scales or mechanical truck scale (single load cell) conversions.

### PERFORMANCE APPLICATIONS

The TS255 Series is specified in industrial applications such as warehousing, recycling, freight, chemical, manufacturing and ag.

### SPECIFICATIONS

Display	1.0" high, 6-digit, green backlit LCD
Enclosure	Black ABS plastic, NEMA 1 rated Stainless steel, NEMA 4X rated
Pushbutton Keys	0-9, Decimal, Enter, ID/Left arrow, Right arrow, Menu, Zero, Print, Units, Tare, On/Off, B/G Net
Units	lb, kg, oz, g, lb-oz or custom
Capacity	Selectable 0 to 999,999
Graduation Size	0.0001 to 50
Load Cells	Up to eight 350Ω cells or 16 1000Ω cells
Power Requirements	Choice of AC or AC/DC (requires 5 "D" cell batteries)
Battery life (backlight enabled)	One 350Ω load cell - 58 hours, Four 350Ω load cells - 33 hours
Mounting	Desk / Wall mount stand (all models)
Output	COM1 (standard): RS232, RS422, RS485 COM2 (standard): RS232, RS422, RS485 and 20 mA; External DB9 on ABS model
Remote switch inputs	Print, Tare, Gross/Net, Units, Zero
Remote switch inputs	Print, Tare, Gross/Net, Units, Zero
Accessories	Bluetooth® wireless technology, 4-20 mA module, Profibus, Ethernet/IP, Ethernet TCP, DeviceNet, ControlNet, Modbus TCP
Approvals	NTEP CC# 15-099, MC #AM-6002, ETL

### SPECIAL FEATURES

- Full-numeric keypad for ID entry and easy configuration.
- Tailor your TS255 using customer units, custom ticket formats and programmable RS232 output.
- Battery power option on both ABS and stainless steel models.
- Accumulation feature eliminates manual tracking.
- Convert any scale into a counting scale by activating the TS255's piece counting feature.
- Comes with stainless steel desktop/wall mount swivel bracket.

### ABS PLASTIC ENCLOSURE

(Stainless steel bracket included — Battery power optional)

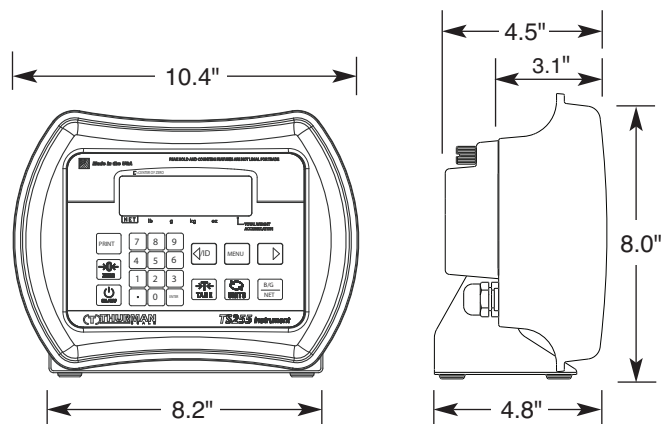

### STAINLESS STEEL ENCLOSURE

(Stainless steel bracket included — Battery power optional)

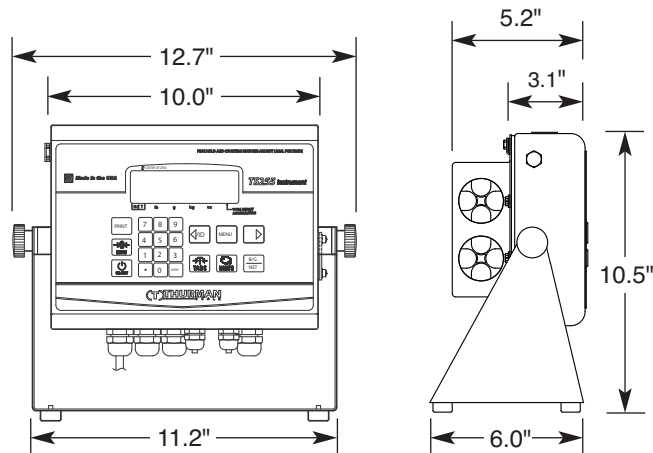

### At A Glance™

Models and specifications subject to change without notice.  
Printed in the USA. © Thurman Scale